



DYNATRON CORPORATION

TOP MOTOR TECHNOLOGY(HUIZHOU)CO,LTD

Specification for Approval

Customer:

Model Number: DF126025BU-PWMG(60*60*25)

Part Number:

Issued Date: Thursday, July 31, 2008

Customer Approval	
Approval:	Check:

Corporate Headquarters
Dynatron Corporation
 42307 Osgood Road, #F,
 Fremont, California 94539,
 U.S.A.
 Tel: 510-498-8888
 Fax: 510-498-8488

Manufactory
**TOP MOTOR TECHNOLOGY(HUI
 ZHOU)CO,LTD**
 Baishi Village, Qiuchang Town,
 Huiyang Dist, Huizhou City, Guangdong
 Province, P.R. China
 Tel: 86-752-353-5591 (Rep.)
 Fax: 86-752-353-5592

Los Angeles Office (U.S.A.)
 337 Paseo Sonrisa,
 Walnut, California 91789
 U.S.A.
 Tel: 909-598-2222
 Fax: 909-598-8158

Taipei Office (Taiwan, R.O.C.)
 8F, No. 35, Lane:221,
 Gang Cian Road, Taipei,
 Taiwan, R.O.C.
 Tel: 886-2-2799-5799(Rep.)
 Fax: 886-2-2799-9577

Approval:	Check:	Initiator:



DYNATRON CORPORATION

TOP MOTOR TECHNOLOGY(HUIZHOU)CO,LTD

	CONTENTS	Page
1.	SCOPE	3
2.	ELECTRICAL CHARACTERISTICS	3
3.	MECHANICAL CHARACTERISTICS	4
4.	ENVIRONMENTAL	4
5.	PROTECTION	5
6.	ATTACHMENTS	5
	a. Assembly Drawing	6
	b. Product Dimension	7
	c. Electrical specifications for pwm production	8-9



DYNATRON CORPORATION

TOP MOTOR TECHNOLOGY(HUIZHOU)CO,LTD

1. SCOPE

This specification defines the electrical and mechanical characteristics of the AC / DC Brush less(Sleeve Bearing / 1-Ball Bearing / 2-Balls Bearing) axial flow fan, which is carefully designed and manufactured for your special needs by Dynatron Corporation.

2. ELECTRICAL CHARACTERISTICS

Items		Description		
1.	Rated Voltage	DC 12 V		
2.	Operating Voltage	12V±10%		
3.	Start Voltage	DC 7V		
4.	PWM 信號主頻 25KHz 幅度 5V	占空比 D=0-20%	占空比 D=50%	占空比 D=100%
5.	Air Flow – At rated voltage zero static pressure (minimal value)	0.2508m ³ / z min (8.855CFM)	0.6223m ³ / min (21.967CFM)	1.3155m ³ / min (46.439CFM)
6.	Static Pressure – At rated voltage At zero air flow	0.875mm-H ₂ O (0.03445inch-H ₂ O)	4.742mm-H ₂ O(0.1867inch-H ₂ O)	19.194mm-H ₂ O (0.7557inch-H ₂ O)
7.	Input Current (Max.)	0.05A	0.15A	0.6A
8.	Speed (Max.)	1700RPM ±200	4000RPM ±15%	8000~8500 RPM
9.	Acoustical Noise	21.8dBA	34.5dBA	52.8dBA
10.	Input Power	0.6W	1.8W	7.2W
11.	Insulation Resistance – Between Frame and Terminal	10 M ohm at DC 500 V		
12.	Dielectric Strength – Between Frame and Terminal	5 mA (Max.) @ AC 500 V 60 Hz 1 min.		
13.	Life – Continuous operating under normal temperature (40 °C or 104 °F)	70,000 hours		
14.	Autorestart Time	3-5sec		
15.	Rotation	Clockwise Air Discharged		



DYNATRON CORPORATION

TOP MOTOR TECHNOLOGY(HUIZHOU)CO,LTD

16.	Lead Wires	UL 1007, awg 28 or Equivalent “-”: Black; “+”: Yellow;”s”: Green. ”PWM”: Blue
-----	------------	--

3. MECHANICAL CHARACTERISTICS

Items		Description
1.	Dimension	Display as Drawing
2.	Frame	PBT UL94V-0 (Black GP)
3.	Impeller	PBT UL94V-0 (Black GP)
4.	Bearing System	Two ball Bearing
5.	Weight	70±5grams

4. ENVIRONMENTAL

Items		Description
1.	Operating Temperature	- 10 °C ~ + 65 °C (65 %RH)
2.	Storage Temperature	- 30 °C ~ + 70 °C (65 %RH)
3.	Vibration Test	Displacement Amplitude: 0.75mm(Equivalent 10G) Frequency Range:10Hz<->55Hz/30SEC. Linear Scanning 120 Cycle Endurance Timer Per Axis:30Min. Orientation:X,Y,Z.
4.	Drop Test	Motor withstands one free body drop from 30 cm in high onto 10 mm thickness of wooden board for each of the three faces in minimum packing condition.
5.	Acoustic Noise	21.8/34.5/52.8dBA – Curve (Max) Measuring Condition – Under rated voltage in semi-anechoic chamber equipment sound level meter. (Figure A.)

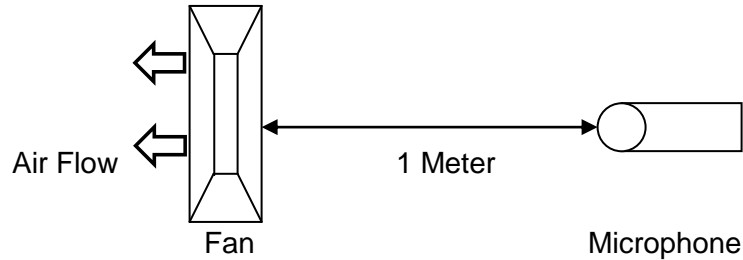

Figure A – Noise Level is measure at rated voltage in anechoic chamber in free air as above.

5. PROTECTION

Items		Description
1.	Polarity Protection	For polarity error connection to power, the circuit withstands reversed connection between positive and negative leads.
2.	Locked Rotor Protection	Motor winding protects the motor from damage in 72 hours of locked rotor condition at rated voltage.

ATTACHMENTS

- a. Assembly Drawing
- b. Product Dimension
- c. Electrical specifications for pwm production

DIMENSIONS:

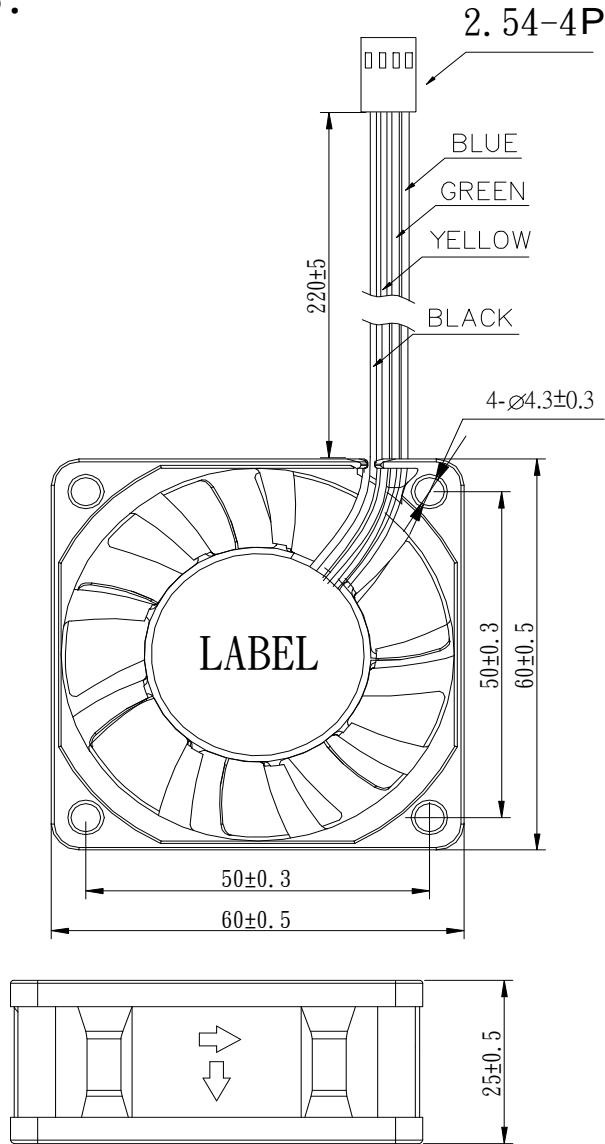

UNIT: MM

1.LEAD WIRE:1007 #28AWG 80°C 300V UL,CSA APPROVAL

 <p>TOP MOTOR</p>	<p>TOP MOTOR TECHNOLOGY (HUIZHOU)CO, LTD</p>	DF126025XX		Tolerance	Vide Supra	Approval	
		Drawing Type	Dimensions	Unit	mm	Check	
				Edition	1.0	Initiator	
				Remark		Date	



DYNATRON CORPORATION

TOP MOTOR TECHNOLOGY(HUIZHOU)CO,LTD

Electrical Specifications for PWM production

Voltage

Fan operating voltage shall be within the range 12V \pm 1.2V.

Current

Peak fan current draw during start-up operation(with 13.2V applied,with fan operating in the free stream condition)shall not exceed 2.0 A.

Fan current spike during start-up operation(with 13.2V applied with fan operating in the free stream condition)shall be allowed to exceed 1.0 A for a duration of no greater than 1.0 sec.

Tachometer Output Signal

Fan shall provide tachometer output signal with the following characteristics:

- * Two pulses per revolution
- * Open-collector or open-drain type output
- * Motherboard will have a pull up to 12V, maximum 13.2V

PWM Control Input Signal

The following requirements are measured at the PWM(control) pin of the fan cable

connector:PWM Frequency:Target frequency 25kHz,

acceptable operational range 21 kHz to 28 KHz

Maximum voltage for logic low:VIL=0.8V

Absolute maximum current sourced:Imax=5mA(short circuit current)

Absolute maximum voltage level:Vmax=5.25V(open circuit voltage)

Fan Speed Control

1.1 Maximum Fan Speed Requirements

The maximum fan speed shall be specified for the fan model by the vendor and correspond to 100% duty cycle PWM signal input.

1.2 Minimum Fan Speed Requirements

The vendor shall specify the minimum RPM and the corresponding PWM duty cycle. This specified minimum RPM shall be 30% of maximum RPM or less. The fan shall be able to start and run at this RPM. To allow a lower specified minimum RPM, it is acceptable to provide a higher PWM duty cycle to the fan motor for a short period of time for startup conditions. This pulse should not exceed 30% maximum RPM and should last no longer than 2 seconds.



DYNATRON CORPORATION

TOP MOTOR TECHNOLOGY(HUIZHOU)CO,LTD

1.3 Fan Speed Response PWM Control Input Signal

The PWM input shall be delivered to the fan through the control signal on Pin4. Fan speed response to this signal shall be a continuous and monotonic of the duty cycle of the signal, from 100% to the minimum specified RPM. The fan RPM (as a percentage of maximum RPM) should match the PWM duty cycle within $\pm 10\%$. If no control signal is present the fan shall operate at maximum RPM.

Figure 1 Fan speed Response to PWM Control input Signal

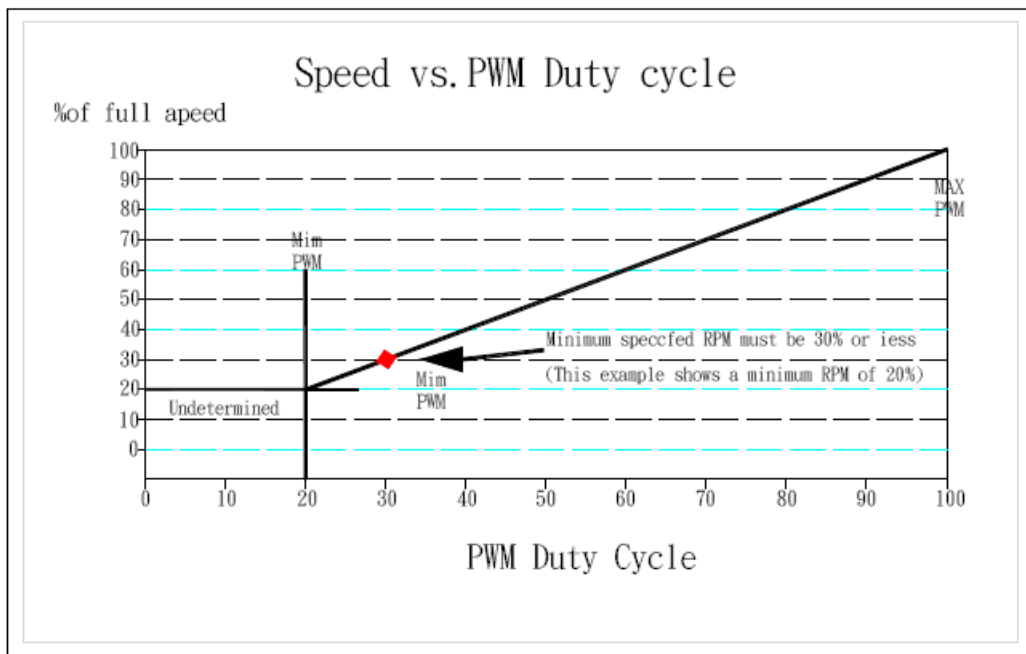

1.4 Operation Below Minimum RPM

For all duty cycles less than the minimum duty cycle, the RPM shall not be greater than the minimum RPM. The following graphs and definitions show three recommended solutions to handle PWM duty cycles that are less than the minimum operational PRM, as a percentage of maximum.

Reference resource by Intel's 4-wire PWM Fan controlled specification.